

H Frame Support System

HFS



Description

The Lindab H frame set is a quick, versatile and economical solution for supporting ductwork, pipework or cable trays. Using the inserts supplied the feet are adapted to accommodate channel support system RPC 41x41 mm (not included in kit).

Construction

The Lindab Big Foot plastic mounting feet for the modular framework system are manufactured from UV protected Nylon 6 B601L 30% Glass fibre filled. Metal components are manufactured from hot dipped galvanised steel and comply with EN10219 S235 J0H, EN10219 S275 J2H & EN10219 S355 J2H.

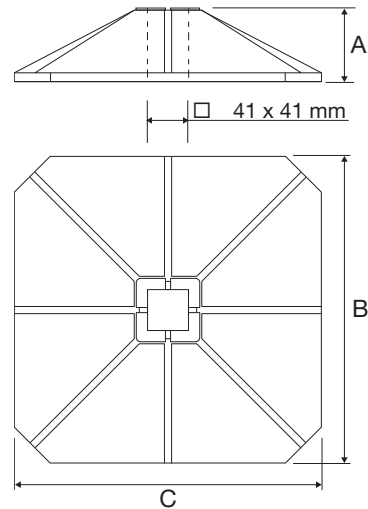

Type	A mm	B mm	C mm	m kg
305	75	305	305	5,0
450	100	450	450	10,0

Kit Includes

- 2 x Feet
- 2 x AV mats
- 2 x Channel inserts
- 2 x L-Brackets
- 4 x M10 Bolts
- 4 x Square channel nuts

Kit does not include channel

Maximum Load

Small feet: 305x305x75 mm
 Maximum load per set: 100 kg
 Large feet: 450x450x100 mm
 Maximum load per set: 150 kg

Ordering example

Product	HFS	305
Dimension		

- 1
- 2
- 3
- 4
- 5
- 6
- 7
- 8
- 9
- 10
- 11
- 12
- 13
- 14
- 15
- 16
- 17
- 18