

## Fluff Separator LN-2

INOX



F  
EU...

### Application

The fluff separator is an air exhaust grille designed for wall mounting in rooms with special air purity demands (operation theatres, computer centres, ...).

It is primarily used for air exhaust.

### Description

The grilles are made of stainless (grinding) sheet steel. The grille face consists of a frame with a closely woven stainless mesh welded on.

The installation frame can accommodate either a filter (LN-2/filter) or an air flow rate adjustment stainless steel insert F (LN-2/F). (To adjust the insert, remove the grille face). Front plate is fastened on the installation frame with the stainless steel screw.

### Installation

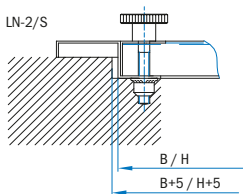

### Filter Insert Cleaning and Replacement:

Due to the build-up of impurities, the grille must be removed and cleaned. Loosen the grille face screw and simply withdraw the grille face from the installation frame.

With the LN-2/filter variant, withdraw the filter insert from the frame and replace it by a new insert.

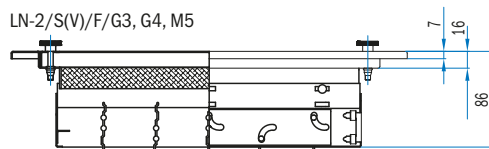
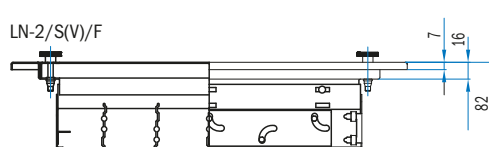
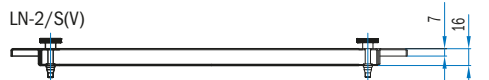
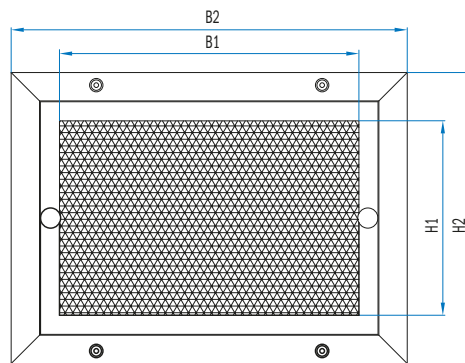
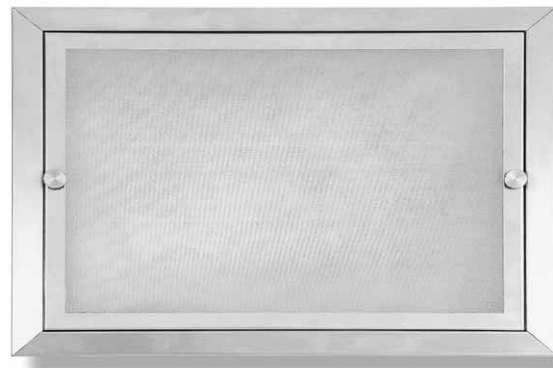

Table 1: Dimensions and weight

Nominal dimension		Free area		Overall dimension		Weight [kg]			
B	H	B1	H1	B2	H2	LN-2/S(V)	LN-2/S(V)/filter	LN-2/S(V)/F	LN-2/S(V)/F/filter
325	225	285	185	377	277	1.2	1.8	2.0	2.6
425	225	385	185	477	277	1.4	2.2	2.4	3.0
525	225	485	185	577	277	1.6	2.5	2.9	3.5
425	325	385	285	477	377	1.6	2.1	2.9	3.2
525	325	485	285	577	377	1.8	2.5	3.4	3.8
625	325	585	285	677	377	2.0	2.9	3.8	4.5

Note: Deviation of weight is ±10 %.

### Ordering key

LN-2 / V / M5 / F B x H

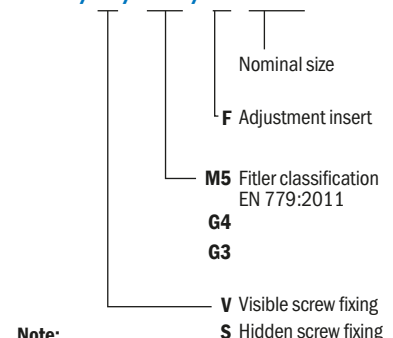

**Note:**

- Filter is included.